

ESP8685-WROOM-04

Datasheet Version 1.5

2.4 GHz Wi-Fi (802.11b/g/n) and Bluetooth® 5 module

Built around ESP8685 series of SoC, RISC-V single-core microprocessor

4 MB flash in chip package

13 GPIOs

On-board PCB antenna



ESP8685-WROOM-04



1 Module Overview

Note:

Check the link or the QR code to make sure that you use the latest version of this document:
https://espressif.com/documentation/esp8685-wroom-04_datasheet_en.pdf



1.1 Features

CPU and On-Chip Memory

- ESP8685H4 embedded, 32-bit RISC-V single-core processor, up to 160 MHz
- 384 KB ROM
- 400 KB SRAM (16 KB for cache)
- 8 KB SRAM in RTC
- 4 MB flash in chip package

Wi-Fi

- IEEE 802.11b/g/n-compliant
 - Center frequency range of operating channel: 2412 ~ 2484 MHz
 - Supports 20 MHz, 40 MHz bandwidth in 2.4 GHz band
 - 1T1R mode with data rate up to 150 Mbps
 - Wi-Fi Multimedia (WMM)
 - TX/RX A-MPDU, TX/RX A-MSDU
 - Immediate Block ACK
 - Fragmentation and defragmentation
 - Transmit opportunity (TXOP)
 - Automatic Beacon monitoring (hardware TSF)
 - 4 × virtual Wi-Fi interfaces
 - Simultaneous support for Infrastructure BSS in Station mode, SoftAP mode, Station + SoftAP mode, and promiscuous mode
- Note that when ESP8685 scans in Station mode, the SoftAP channel will change along with the Station channel*

- 802.11mc FTM

Bluetooth®

- Bluetooth LE: Bluetooth 5, Bluetooth mesh
- Speed: 125 Kbps, 500 Kbps, 1 Mbps, 2 Mbps
- Advertising extensions
- Multiple advertisement sets
- Channel selection algorithm #2
- Internal co-existence mechanism between Wi-Fi and Bluetooth to share the same antenna

Peripherals

- Up to 13 GPIOs
 - 3 strapping GPIOs
- SPI, UART, I2C, I2S, remote control peripheral, LED PWM controller, general DMA controller, TWAI® controller (compatible with ISO 11898-1, i.e. CAN Specification 2.0), USB Serial/JTAG controller, temperature sensor, SAR ADC, general-purpose timers, watchdog timers

Note:

* Please refer to [ESP8685 Series Datasheet](#) for detailed information about the module peripherals.

Integrated Components on Module

- 40 MHz crystal oscillator

Antenna Options

- On-board PCB antenna

Operating Conditions

- Operating voltage/Power supply: 3.0 ~ 3.6 V
- Operating ambient temperature: -40 ~ 105 °C

- Green certification: RoHS/REACH

Test

- HTOL/HTSL/uHAST/TCT/ESD

Certification

- RF certification: See [certificates](#)

1.2 Series Comparison

ESP8685-WROOM-04 is a powerful, generic Wi-Fi and Bluetooth LE module that has a rich set of peripherals. This module is an ideal choice for smart homes, industrial automation, health care, consumer electronics, etc.

ESP8685-WROOM-04 comes with an on-board PCB antenna.

The series comparison for ESP8685-WROOM-04 is as follows:

Table 1-1. ESP8685-WROOM-04 Series Comparison

Ordering Code	Flash	Ambient Temp. ¹ (°C)	Size ² (mm)
ESP8685-WROOM-04-H4	4 MB (Quad SPI) ^{3, 4}	-40 ~ 105	24.0 × 16.0 × 3.1

¹ Ambient temperature specifies the recommended temperature range of the environment immediately outside the Espressif module.

² For details, refer to Section [10 Module Dimensions](#).

³ The flash is in the chip package. For specifications, refer to Section [6.5 Memory Specifications](#).

⁴ By default, the SPI flash on the module operates at a maximum clock frequency of 80 MHz and does not support the auto suspend feature. If you have a requirement for a higher flash clock frequency of 120 MHz or if you need the flash auto suspend feature, please [contact us](#).

At the core of this module is the ESP8685H4 chip. ESP8685 series of chips have a 32-bit RISC-V single-core processor. They integrate a rich set of peripherals, ranging from UART, I2C, I2S, remote control peripheral, LED PWM controller, general DMA controller, TWAI® controller, USB Serial/JTAG controller, temperature sensor, and ADC.

Note:

For more information on ESP8685 chip series, please refer to [ESP8685 Series Datasheet](#).

1.3 Applications

- Smart Home
- Industrial Automation
- Health Care
- Consumer Electronics
- Smart Agriculture
- POS Machines
- Service Robot
- Audio Devices

- Generic Low-power IoT Sensor Hubs
- Generic Low-power IoT Data Loggers

Contents

1	Module Overview	2
1.1	Features	2
1.2	Series Comparison	3
1.3	Applications	3
2	Block Diagram	9
3	Pin Definitions	10
3.1	Pin Layout	10
3.2	Pin Description	10
4	Boot Configurations	12
4.1	Chip Boot Mode Control	13
4.2	ROM Messages Printing Control	14
4.3	Chip Power-up and Reset	14
5	Peripherals	16
5.1	Peripheral Overview	16
5.2	Peripheral Description	16
5.2.1	Connectivity Interface	16
5.2.1.1	UART Controller	16
5.2.1.2	SPI Controller	16
5.2.1.3	I2C Controller	17
5.2.1.4	I2S Controller	18
5.2.1.5	USB Serial/JTAG Controller	18
5.2.1.6	Two-wire Automotive Interface	18
5.2.1.7	LED PWM Controller	19
5.2.1.8	Remote Control Peripheral	19
5.2.2	Analog Signal Processing	19
5.2.2.1	SAR ADC	20
5.2.2.2	Temperature Sensor	20
6	Electrical Characteristics	21
6.1	Absolute Maximum Ratings	21
6.2	Recommended Operating Conditions	21
6.3	DC Characteristics (3.3 V, 25 °C)	21
6.4	Current Consumption Characteristics	22
6.4.1	RF Current Consumption in Active Mode	22
6.4.2	Current Consumption in Other Modes	22
6.5	Memory Specifications	23
7	RF Characteristics	24
7.1	Wi-Fi Radio	24

7.1.1	Wi-Fi RF Transmitter (TX) Characteristics	24
7.1.2	Wi-Fi RF Receiver (RX) Characteristics	25
7.2	Bluetooth 5 (LE) Radio	26
7.2.1	Bluetooth LE RF Transmitter (TX) Characteristics	26
7.2.2	Bluetooth LE RF Receiver (RX) Characteristics	28
8	Module Schematics	30
9	Peripheral Schematics	31
10	Module Dimensions	32
11	PCB Layout Recommendations	33
11.1	PCB Land Pattern	33
11.2	Module Placement for PCB Design	33
12	Product Handling	35
12.1	Storage Conditions	35
12.2	Electrostatic Discharge (ESD)	35
12.3	Reflow Profile	35
12.4	Ultrasonic Vibration	36
	Datasheet Versioning	37
	Related Documentation and Resources	38
	Revision History	39

List of Tables

1-1	ESP8685-WROOM-04 Series Comparison	3
3-1	Pin Definitions	11
4-1	Default Configuration of Strapping Pins	12
4-2	Description of Timing Parameters for the Strapping Pins	13
4-3	Chip Boot Mode Control	13
4-4	UART0 ROM Message Printing Control	14
4-5	USB Serial/JTAG ROM Message Printing Control	14
4-6	Description of Timing Parameters for Power-up and Reset	15
6-1	Absolute Maximum Ratings	21
6-2	Recommended Operating Conditions	21
6-3	DC Characteristics (3.3 V, 25 °C)	21
6-4	Current Consumption for Wi-Fi (2.4 GHz) in Active Mode	22
6-5	Current Consumption in Modem-sleep Mode	22
6-6	Current Consumption in Low-Power Modes	23
6-7	Flash Specifications	23
7-1	Wi-Fi RF Characteristics	24
7-2	TX Power with Spectral Mask and EVM Meeting 802.11 Standards	24
7-3	TX EVM Test	24
7-4	RX Sensitivity	25
7-5	Maximum RX Level	26
7-6	RX Adjacent Channel Rejection	26
7-7	Bluetooth LE RF Characteristics	26
7-8	Bluetooth LE - Transmitter Characteristics - 1 Mbps	26
7-9	Bluetooth LE - Transmitter Characteristics - 2 Mbps	27
7-10	Bluetooth LE - Transmitter Characteristics - 125 Kbps	27
7-11	Bluetooth LE - Transmitter Characteristics - 500 Kbps	27
7-12	Bluetooth LE - Receiver Characteristic - 1 Mbps	28
7-13	Bluetooth LE - Receiver Characteristic - 2 Mbps	28
7-14	Bluetooth LE - Receiver Characteristic - 125 Kbps	29
7-15	Bluetooth LE - Receiver Characteristic - 500 Kbps	29

List of Figures

2-1	Block Diagram	9
3-1	Pin Layout (Top View)	10
4-1	Visualization of Timing Parameters for the Strapping Pins	13
4-2	Visualization of Timing Parameters for Power-up and Reset	15
8-1	Schematics	30
9-1	Peripheral Schematics	31
10-1	Physical Dimensions	32
11-1	Recommended PCB Land Pattern	33
12-1	Reflow Profile	35

2 Block Diagram

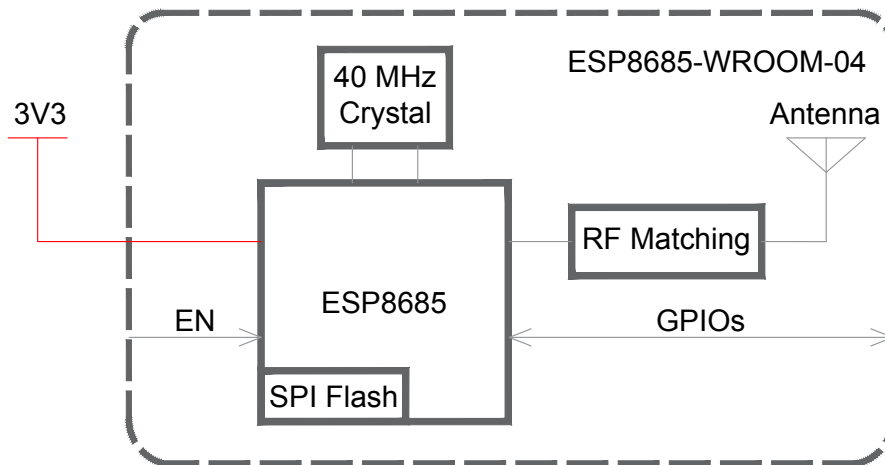

Figure 2-1. Block Diagram

3 Pin Definitions

3.1 Pin Layout

The pin diagram below shows the approximate location of pins on the module. For the actual diagram drawn to scale, please refer to Figure 10 *Module Dimensions*.

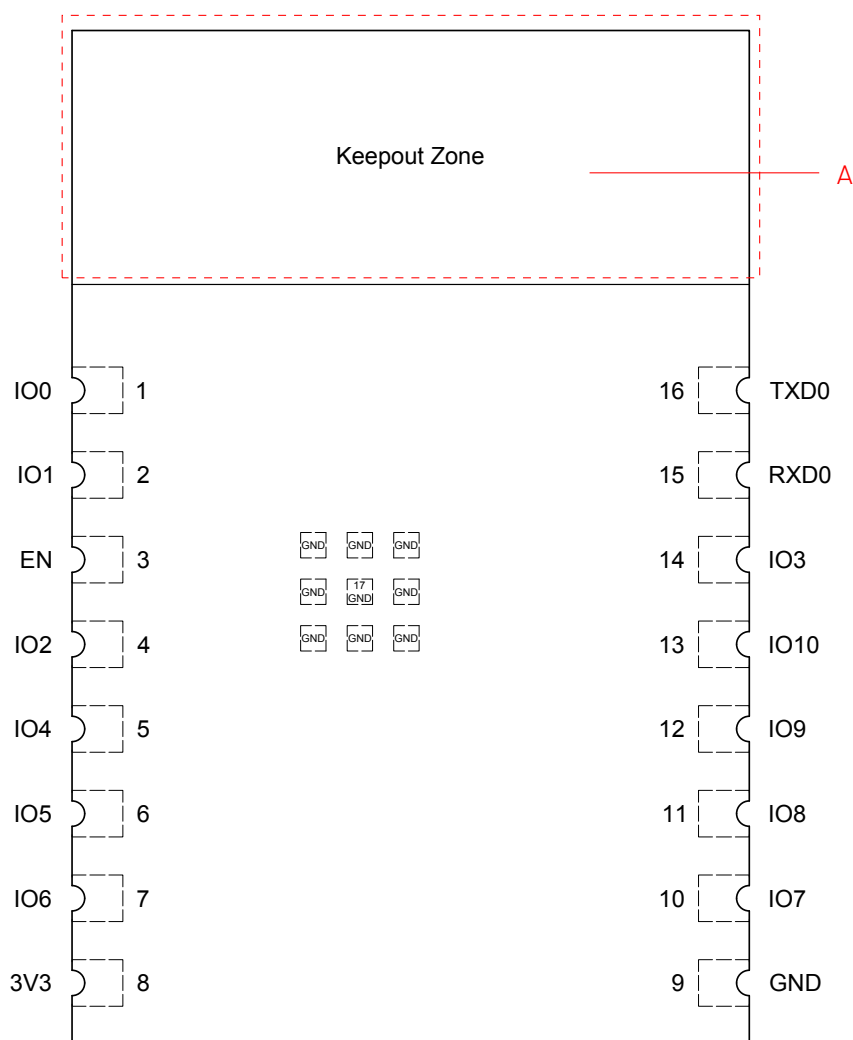

Figure 3-1. Pin Layout (Top View)

Note A:

The zone marked with dotted lines is the antenna keepout zone. To learn more about the keepout zone for module's antenna on the base board, please refer to [ESP32-C3 Hardware Design Guidelines](#) > Section *General Principles of PCB Layout for Modules*.

3.2 Pin Description

The module has 17 pins. See pin definitions in Table 3-1 *Pin Definitions*.

For peripheral pin configurations, please refer to [ESP8685 Series Datasheet](#).

Table 3-1. Pin Definitions

Name	No.	Type ¹	Function
IO0	1	I/O/T	GPIO0, ADC1_CH0, XTAL_32K_P
IO1	2	I/O/T	GPIO1, ADC1_CH1, XTAL_32K_N
EN	3	I	High: on, enables the chip. Low: off, the chip powers off. By default, this pin is internally pulled high.
IO2	4	I/O/T	GPIO2, ADC1_CH2, FSPIQ
IO4	5	I/O/T	GPIO4, ADC1_CH4, FSPIHD, MTMS, LED PWM
IO5	6	I/O/T	GPIO5, ADC2_CH0, FSPIWP, MTDI, LED PWM
IO6	7	I/O/T	GPIO6, FSPICLK, MTCK, LED PWM
3V3	8	P	Power supply
GND	9,17	P	Ground
IO7	10	I/O/T	GPIO7, FSPID, MTDO, LED PWM
IO8	11	I/O/T	GPIO8
IO9	12	I/O/T	GPIO9
IO10	13	I/O/T	GPIO10, FSPICSO, LED PWM
IO3	14	I/O/T	GPIO3, ADC1_CH3, LED PWM
RXD0	15	I/O/T	GPIO20, UORXD
TXD0	16	I/O/T	GPIO21, UOTXD

¹ P: power supply; I: input; O: output; T: high impedance.

4 Boot Configurations

Note:

The content below is excerpted from [ESP8685 Series Datasheet](#) > Chapter *Boot Configurations*. For the strapping pin mapping between the chip and modules, please refer to Chapter [8 Module Schematics](#).

The chip allows for configuring the following boot parameters through strapping pins and eFuse parameters at power-up or a hardware reset, without microcontroller interaction.

- **Chip boot mode**
 - Strapping pins: GPIO2, GPIO8, and GPIO9
- **ROM message printing**
 - Strapping pin: GPIO8
 - eFuse parameters: EFUSE_UART_PRINT_CONTROL and EFUSE_USB_PRINT_CHANNEL

The default values of all the above eFuse parameters are 0, which means that they are not burnt. Given that eFuse is one-time programmable, once programmed to 1, it can never be reverted to 0. For how to program eFuse parameters, please refer to [ESP32-C3 Technical Reference Manual](#) > Chapter *eFuse Controller*.

The default values of the strapping pins, namely the logic levels, are determined by pins' internal weak pull-up/pull-down resistors at reset if the pins are not connected to any circuit, or connected to an external high-impedance circuit.

Table 4-1. Default Configuration of Strapping Pins

Strapping Pin	Default Configuration	Bit Value
GPIO2	Floating	–
GPIO8	Floating	–
GPIO9	Weak pull-up	1

To change the bit values, the strapping pins should be connected to external pull-down/pull-up resistances. If the ESP8685 is used as a device by a host MCU, the strapping pin voltage levels can also be controlled by the host MCU.

All strapping pins have latches. At Chip Reset, the latches sample the bit values of their respective strapping pins and store them until the chip is powered down or shut down. The states of latches cannot be changed in any other way. It makes the strapping pin values available during the entire chip operation, and the pins are freed up to be used as regular IO pins after reset. For details on Chip Reset, see [ESP32-C3 Technical Reference Manual](#) > Chapter *Reset and Clock*.

The timing of signals connected to the strapping pins should adhere to the *setup time* and *hold time* specifications in Table [4-2](#) and Figure [4-1](#).

Table 4-2. Description of Timing Parameters for the Strapping Pins

Parameter	Description	Min (ms)
t_{SU}	Setup time is the time reserved for the power rails to stabilize before the CHIP_EN pin is pulled high to activate the chip.	0
t_H	Hold time is the time reserved for the chip to read the strapping pin values after CHIP_EN is already high and before these pins start operating as regular IO pins.	3

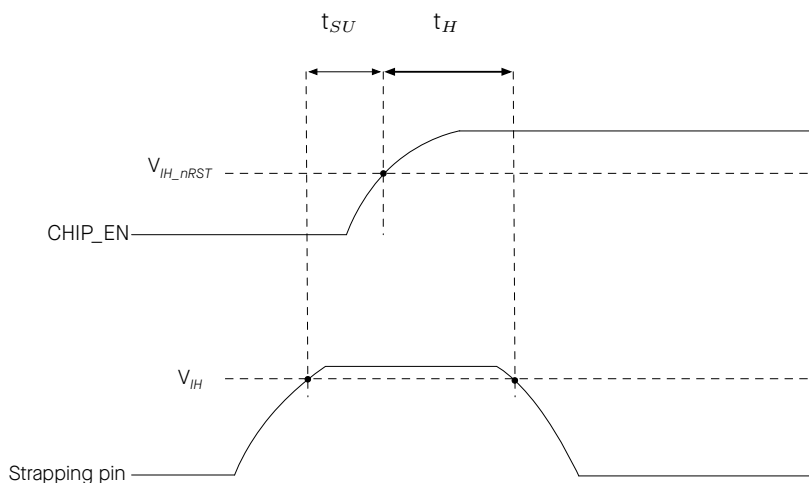

Figure 4-1. Visualization of Timing Parameters for the Strapping Pins

4.1 Chip Boot Mode Control

GPIO2, GPIO8, and GPIO9 control the boot mode after the reset is released. See Table 4-3 *Chip Boot Mode Control*.

Table 4-3. Chip Boot Mode Control

Boot Mode	GPIO2 ²	GPIO8	GPIO9
SPI boot mode	1	Any value	1
Joint download boot mode ³	1	1	0

¹ **Bold** marks the default value and configuration.

² GPIO2 actually does not determine SPI Boot and Joint Download Boot mode, but it is recommended to pull this pin up due to glitches.

³ Joint Download Boot mode supports the following download methods:

- USB-Serial-JTAG Download Boot
- UART Download Boot

In SPI Boot mode, the ROM bootloader loads and executes the program from SPI flash to boot the system.

In Joint Download Boot mode, users can download binary files into flash using UART0 or USB interface. It is also possible to download binary files into SRAM and execute it from SRAM.

In addition to SPI Boot and Joint Download Boot modes, ESP8685 also supports SPI Download Boot mode. For details, please see [ESP32-C3 Technical Reference Manual](#) > Chapter *Chip Boot Control*.

4.2 ROM Messages Printing Control

During the boot process, the messages by the ROM code can be printed to:

- **(Default) UART0 and USB Serial/JTAG controller**
- UART0
- USB Serial/JTAG controller

EFUSE_UART_PRINT_CONTROL and GPIO8 control ROM messages printing to **UART0** as shown in Table 4-4 *UART0 ROM Message Printing Control*.

Table 4-4. UART0 ROM Message Printing Control

UART0 ROM Code Printing	EFUSE_UART_PRINT_CONTROL	GPIO8
Enabled	0	Ignored
	1	0
	2	1
Disabled	1	1
	2	0
	3	Ignored

¹ **Bold** marks the default value and configuration.

EFUSE_USB_PRINT_CHANNEL controls the printing to **USB Serial/JTAG controller** as shown in Table 4-5 *USB Serial/JTAG ROM Message Printing Control*.

Table 4-5. USB Serial/JTAG ROM Message Printing Control

USB Serial/JTAG ROM Code Printing	EFUSE_DIS_USB_SERIAL_JTAG ²	EFUSE_USB_PRINT_CHANNEL
Enabled	0	0
Disabled	0	1
	1	Ignored

¹ **Bold** marks the default value and configuration.

² EFUSE_DIS_USB_SERIAL_JTAG controls whether to disable USB Serial/JTAG.

4.3 Chip Power-up and Reset

Once the power is supplied to the chip, its power rails need a short time to stabilize. After that, CHIP_EN – the pin used for power-up and reset – is pulled high to activate the chip. For information on CHIP_EN as well as power-up and reset timing, see Figure 4-2 and Table 4-6.

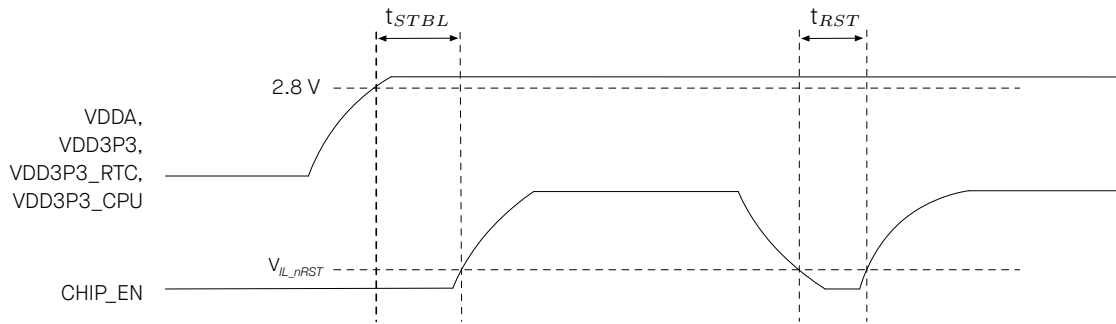

Figure 4-2. Visualization of Timing Parameters for Power-up and Reset

Table 4-6. Description of Timing Parameters for Power-up and Reset

Parameter	Description	Min (μs)
t_{STBL}	Time reserved for the power rails of VDDA, VDD3P3, VDD3P3_RTC, and VDD3P3_CPU to stabilize before the CHIP_EN pin is pulled high to activate the chip	50
t_{RST}	Time reserved for CHIP_EN to stay below V_{IL_nRST} to reset the chip (see Table 6-3)	50

5 Peripherals

5.1 Peripheral Overview

ESP8685H4 integrates a rich set of peripherals including SPI, I2S, UART, I2C, RMT, LED PWM controller, TWAI® controller, USB Serial/JTAG controller, temperature sensor, etc.

To learn more about on-chip components, please refer to [ESP8685 Series Datasheet](#) > Section *Functional Description*.

Note:

The content below is sourced from [ESP8685 Series Datasheet](#) > Section *Peripherals*. Some information may not be applicable to ESP8685-WROOM-04 as not all the IO signals are exposed on the module.

To learn more about peripheral signals, please refer to [ESP32-C3 Technical Reference Manual](#) > Section *Peripheral Signal List*.

5.2 Peripheral Description

This section describes the chip's peripheral capabilities, covering connectivity interfaces and on-chip sensors that extend its functionality.

5.2.1 Connectivity Interface

This subsection describes the connectivity interfaces on the chip that enable communication and interaction with external devices and networks.

5.2.1.1 UART Controller

ESP8685 has two UART interfaces, i.e. UART0 and UART1, which support IrDA and asynchronous communication (RS232 and RS485) at a speed of up to 5 Mbps. The UART controller provides hardware flow control (CTS and RTS signals) and software flow control (XON and XOFF). Both UART interfaces connect to GDMA via UHCIO, and can be accessed by the GDMA controller or directly by the CPU.

For details, see [ESP32-C3 Technical Reference Manual](#) > Chapter *UART Controller (UART, LP_UART)*.

Pin Assignment

For details, see [ESP8685 Series Datasheet](#) > Section *Peripheral Pin Assignment*.

5.2.1.2 SPI Controller

ESP8685 has the following SPI interfaces:

- **SPI0** used by ESP8685's GDMA controller and cache to access in-package flash
- **SPI1** used by the CPU to access in-package flash
- **SPI2** is a general purpose SPI controller with access to a DMA channel allocated by the GDMA controller

Features of SPI0 and SPI1

- Supports Single SPI, Dual SPI, and Quad SPI, QPI modes
- Configurable clock frequency with a maximum of 120 MHz in Single Transfer Rate (STR) mode
- Data transmission is in bytes

Features of SPI2

- Supports operation as a master or slave
- Connects to a DMA channel allocated by the GDMA controller
- Supports Single SPI, Dual SPI, and Quad SPI, QPI
- Configurable clock polarity (CPOL) and phase (CPHA)
- Configurable clock frequency
- Data transmission is in bytes
- Configurable read and write data bit order: most-significant bit (MSB) first, or least-significant bit (LSB) first
- As a master
 - Supports 2-line full-duplex communication with clock frequency up to 80 MHz
 - Supports 1-, 2-, 4-line half-duplex communication with clock frequency up to 80 MHz
 - Provides six SPI_CS pins for connection with six independent SPI slaves
 - Configurable CS setup time and hold time
- As a slave
 - Supports 2-line full-duplex communication with clock frequency up to 60 MHz
 - Supports 1-, 2-, 4-line half-duplex communication with clock frequency up to 60 MHz

For details, see [ESP32-C3 Technical Reference Manual](#) > Chapter *SPI Controller (SPI)*.

Pin Assignment

For details, see [ESP8685 Series Datasheet](#) > Section *Peripheral Pin Assignment*.

5.2.1.3 I2C Controller

ESP8685 has an I2C bus interface which is used for I2C master mode or slave mode, depending on your configuration. The I2C interface supports:

- standard mode (100 Kbit/s)
- fast mode (400 Kbit/s)
- up to 800 Kbit/s (constrained by SCL and SDA pull-up strength)
- 7-bit and 10-bit addressing mode
- double addressing mode

- 7-bit broadcast address

For details, see [ESP32-C3 Technical Reference Manual](#) > Chapter *I2C Controller (I2C)*.

Pin Assignment

For details, see [ESP8685 Series Datasheet](#) > Section *Peripheral Pin Assignment*.

5.2.1.4 I2S Controller

ESP8685 includes a standard I2S interface. This interface can operate as a master or a slave in full-duplex mode or half-duplex mode, and can be configured for 8-bit, 16-bit, 24-bit, or 32-bit serial communication. BCK clock frequency, from 10 kHz up to 40 MHz, is supported.

The I2S interface connects to the GDMA controller. The interface supports TDM PCM, TDM MSB alignment, TDM standard, and PDM standard.

For details, see [ESP32-C3 Technical Reference Manual](#) > Chapter *I2S Controller (I2S)*.

Pin Assignment

For details, see [ESP8685 Series Datasheet](#) > Section *Peripheral Pin Assignment*.

5.2.1.5 USB Serial/JTAG Controller

ESP8685 integrates a USB Serial/JTAG controller. This controller has the following features:

- CDC-ACM virtual serial port and JTAG adapter functionality
- USB 2.0 full speed compliant, capable of up to 12 Mbit/s transfer speed (Note that this controller does not support the faster 480 Mbit/s high-speed transfer mode)
- programming in-package flash
- CPU debugging with compact JTAG instructions
- a full-speed USB PHY integrated in the chip

For details, see [ESP32-C3 Technical Reference Manual](#) > Chapter *USB Serial/JTAG Controller (USB_SERIAL_JTAG)*.

Pin Assignment

For details, see [ESP8685 Series Datasheet](#) > Section *Peripheral Pin Assignment*.

5.2.1.6 Two-wire Automotive Interface

ESP8685 has a TWAI[®] controller with the following features:

- compatible with ISO 11898-1 protocol (CAN Specification 2.0)
- standard frame format (11-bit ID) and extended frame format (29-bit ID)
- bit rates from 1 Kbit/s to 1 Mbit/s
- multiple modes of operation: Normal, Listen Only, and Self-Test (no acknowledgment required)

- 64-byte receive FIFO
- acceptance filter (single and dual filter modes)
- error detection and handling: error counters, configurable error interrupt threshold, error code capture, arbitration lost capture

For details, see [ESP32-C3 Technical Reference Manual](#) > Chapter *Two-wire Automotive Interface*.

Pin Assignment

For details, see [ESP8685 Series Datasheet](#) > Section *Peripheral Pin Assignment*.

5.2.1.7 LED PWM Controller

The LED PWM controller can generate independent digital waveform on six channels. The LED PWM controller:

- Can generate digital waveform with configurable periods and duty cycle. The resolution of duty cycle can be up to 14 bits.
- Has multiple clock sources, including APB clock and external main crystal clock.
- Can operate when the CPU is in Light-sleep mode.
- Supports gradual increase or decrease of duty cycle, which is useful for the LED RGB color-gradient generator.

For details, see [ESP32-C3 Technical Reference Manual](#) > Chapter *LED PWM Controller*.

Pin Assignment

For details, see [ESP8685 Series Datasheet](#) > Section *Peripheral Pin Assignment*.

5.2.1.8 Remote Control Peripheral

The Remote Control Peripheral (RMT) supports two channels of infrared remote transmission and two channels of infrared remote reception. By controlling pulse waveform through software, it supports various infrared and other single wire protocols. All four channels share a 192 × 32-bit memory block to store transmit or receive waveform.

For more details, see [ESP32-C3 Technical Reference Manual](#) > Chapter *Remote Control Peripheral (RMT)*.

Pin Assignment

For details, see [ESP8685 Series Datasheet](#) > Section *Peripheral Pin Assignment*.

5.2.2 Analog Signal Processing

This subsection describes components on the chip that sense and process real-world data.

5.2.2.1 SAR ADC

ESP8685 integrates two 12-bit SAR ADCs.

- ADC1 supports measurements on 5 channels, and is factory-calibrated.
- ADC2 supports measurements on 1 channel, and is not factory-calibrated.

Note:

ADC2 of some chip revisions is not operable. For details, please refer to [ESP32-C3 Series SoC Errata](#).

For more details, see [ESP32-C3 Technical Reference Manual](#) > Chapter *On-Chip Sensors and Analog Signal Processing*.

Pin Assignment

For details, see [ESP8685 Series Datasheet](#) > Section *Peripheral Pin Assignment*.

5.2.2.2 Temperature Sensor

The temperature sensor generates a voltage that varies with temperature. The voltage is internally converted via an ADC into a digital value.

The temperature sensor has a range of $-40\text{ }^{\circ}\text{C}$ to $125\text{ }^{\circ}\text{C}$. It is designed primarily to sense the temperature changes inside the chip. The temperature value depends on factors like microcontroller clock frequency or I/O load. Generally, the chip's internal temperature is higher than the operating ambient temperature.

For more details, see [ESP32-C3 Technical Reference Manual](#) > Chapter *On-Chip Sensors and Analog Signal Processing*.

6 Electrical Characteristics

6.1 Absolute Maximum Ratings

Stresses above those listed in Table 6-1 *Absolute Maximum Ratings* may cause permanent damage to the device. These are stress ratings only and functional operation of the device at these or any other conditions beyond those indicated under Table 6-2 *Recommended Operating Conditions* is not implied. Exposure to absolute-maximum-rated conditions for extended periods may affect device reliability.

Table 6-1. Absolute Maximum Ratings

Symbol	Parameter	Min	Max	Unit
VDD33	Power supply voltage	-0.3	3.6	V
T _{STORE}	Storage temperature	-40	105	°C

6.2 Recommended Operating Conditions

Table 6-2. Recommended Operating Conditions

Symbol	Parameter	Min	Typ	Max	Unit
VDD33	Power supply voltage	3.0	3.3	3.6	V
I _{VDD}	Current delivered by external power supply	0.5	—	—	A
T _A	Operating ambient temperature	-40	—	105	°C

6.3 DC Characteristics (3.3 V, 25 °C)

Table 6-3. DC Characteristics (3.3 V, 25 °C)

Parameter	Description	Min	Typ	Max	Unit
C _{IN}	Pin capacitance	—	2	—	pF
V _{IH}	High-level input voltage	0.75 × VDD ¹	—	VDD ¹ + 0.3	V
V _{IL}	Low-level input voltage	-0.3	—	0.25 × VDD ¹	V
I _{IH}	High-level input current	—	—	50	nA
I _{IL}	Low-level input current	—	—	50	nA
V _{OH} ²	High-level output voltage	0.8 × VDD ¹	—	—	V
V _{OL} ²	Low-level output voltage	—	—	0.1 × VDD ¹	V
I _{OH}	High-level source current (VDD ¹ = 3.3 V, V _{OH} ≥ 2.64 V, PAD_DRIVER = 3)	—	40	—	mA
I _{OL}	Low-level sink current (VDD ¹ = 3.3 V, V _{OL} = 0.495 V, PAD_DRIVER = 3)	—	28	—	mA
R _{PU}	Internal weak pull-up resistor	—	45	—	kΩ
R _{PD}	Internal weak pull-down resistor	—	45	—	kΩ
V _{IH_nRST}	Chip reset release voltage (CHIP_EN voltage is within the specified range)	0.75 × VDD ¹	—	VDD ¹ + 0.3	V

V_{IL_nRST}	Chip reset voltage (CHIP_EN voltage is within the specified range)	-0.3	—	$0.25 \times VDD^1$	V
----------------	--	------	---	---------------------	---

¹ VDD – voltage from a power pin of a respective power domain.

² V_{OH} and V_{OL} are measured using high-impedance load.

6.4 Current Consumption Characteristics

6.4.1 RF Current Consumption in Active Mode

The current consumption measurements are taken with a 3.3 V supply at 25 °C ambient temperature.

TX current consumption is rated at a 100% duty cycle.

RX current consumption is rated when the peripherals are disabled and the CPU idle.

Table 6-4. Current Consumption for Wi-Fi (2.4 GHz) in Active Mode

Work mode	RF Condition	Description	Peak (mA)
Active (RF working)	TX	802.11b, 1 Mbps, @20 dBm	330
		802.11g, 54 Mbps, @17.5 dBm	280
		802.11n, HT20, MCS7, @17 dBm	275
		802.11n, HT40, MCS7, @16.5 dBm	202
	RX	802.11b/g/n, HT20	82
		802.11n, HT40	84.5

Note:

The content below is excerpted from Section *Power Consumption in Other Modes* in [ESP8685 Series Datasheet](#).

6.4.2 Current Consumption in Other Modes

Table 6-5. Current Consumption in Modem-sleep Mode

Mode	CPU Frequency (MHz)	Description	Typ	
			All Peripherals Clocks Disabled (mA)	All Peripherals Clocks Enabled (mA) ¹
Modem-sleep ^{2,3}	160	CPU is running	23	28
		CPU is idle	16	21
	80	CPU is running	17	22
		CPU is idle	13	18

¹ In practice, the current consumption might be different depending on which peripherals are enabled.

² In Modem-sleep mode, Wi-Fi is clock gated.

³ In Modem-sleep mode, the consumption might be higher when accessing flash. For a flash rated at 80 Mbit/s, in SPI 2-line mode the consumption is 10 mA.

Table 6-6. Current Consumption in Low-Power Modes

Mode	Description	Typ (μA)
Light-sleep	Wi-Fi are powered down, and all GPIOs are high-impedance	130
Deep-sleep	RTC timer + RTC memory	5
Power off	CHIP_EN is set to low level, the chip is powered off	1

6.5 Memory Specifications

The data below is sourced from the memory vendor datasheet. These values are guaranteed through design and/or characterization but are not fully tested in production. Devices are shipped with the memory erased.

Table 6-7. Flash Specifications

Parameter	Description	Min	Typ	Max	Unit
VCC	Power supply voltage (1.8 V)	1.65	1.80	2.00	V
	Power supply voltage (3.3 V)	2.7	3.3	3.6	V
F_C	Maximum clock frequency	80	—	—	MHz
—	Program/erase cycles	100,000	—	—	cycles
T_{RET}	Data retention time	20	—	—	years
T_{PP}	Page program time	—	0.8	5	ms
T_{SE}	Sector erase time (4 KB)	—	70	500	ms
T_{BE1}	Block erase time (32 KB)	—	0.2	2	s
T_{BE2}	Block erase time (64 KB)	—	0.3	3	s
T_{CE}	Chip erase time (16 Mb)	—	7	20	s
	Chip erase time (32 Mb)	—	20	60	s
	Chip erase time (64 Mb)	—	25	100	s
	Chip erase time (128 Mb)	—	60	200	s
	Chip erase time (256 Mb)	—	70	300	s

7 RF Characteristics

This section contains tables with RF characteristics of the Espressif product.

The RF data is measured at the antenna port, where RF cable is connected, including the front-end loss.

Devices should operate in the center frequency range allocated by regional regulatory authorities. The target center frequency range and the target transmit power are configurable by software. See [ESP RF Test Tool and Test Guide](#) for instructions.

Unless otherwise stated, the RF tests are conducted with a 3.3 V ($\pm 5\%$) supply at 25 °C ambient temperature.

7.1 Wi-Fi Radio

Table 7-1. Wi-Fi RF Characteristics

Name	Description
Center frequency range of operating channel	2412 ~ 2484 MHz
Wi-Fi wireless standard	IEEE 802.11b/g/n

7.1.1 Wi-Fi RF Transmitter (TX) Characteristics

Table 7-2. TX Power with Spectral Mask and EVM Meeting 802.11 Standards

Rate	Min (dBm)	Typ (dBm)	Max (dBm)
802.11b, 1 Mbps	—	20.0	—
802.11b, 11 Mbps	—	20.0	—
802.11g, 6 Mbps	—	19.5	—
802.11g, 54 Mbps	—	17.5	—
802.11n, HT20, MCS0	—	18.5	—
802.11n, HT20, MCS7	—	17.0	—
802.11n, HT40, MCS0	—	18.0	—
802.11n, HT40, MCS7	—	16.5	—

Table 7-3. TX EVM Test

Rate	Min (dB)	Typ (dB)	SL ¹ (dB)
802.11b, 1 Mbps, @20 dBm	—	-25.5	-10
802.11b, 11 Mbps, @20 dBm	—	-25.5	-10
802.11g, 6 Mbps, @19.5 dBm	—	-24.0	-5
802.11g, 54 Mbps, @17.5 dBm	—	-29.5	-25
802.11n, HT20, MCS0, @18.5 dBm	—	-24.5	-5

Cont'd on next page

Table 7-3 – cont'd from previous page

Rate	Min (dB)	Typ (dB)	SL ¹ (dB)
802.11n, HT20, MCS7, @17 dBm	—	-30.0	-27
802.11n, HT40, MCS0, @18 dBm	—	-27.0	-5
802.11n, HT40, MCS7, @16.5 dBm	—	-30.0	-27

¹ SL stands for standard limit value.

7.1.2 Wi-Fi RF Receiver (RX) Characteristics

For RX tests, the PER (packet error rate) limit is 8% for 802.11b, and 10% for 802.11g/n.

Table 7-4. RX Sensitivity

Rate	Min (dBm)	Typ (dBm)	Max (dBm)
802.11b, 1 Mbps	—	-98.0	—
802.11b, 2 Mbps	—	-96.0	—
802.11b, 5.5 Mbps	—	-93.0	—
802.11b, 11 Mbps	—	-88.6	—
802.11g, 6 Mbps	—	-92.8	—
802.11g, 9 Mbps	—	-92.0	—
802.11g, 12 Mbps	—	-90.5	—
802.11g, 18 Mbps	—	-88.0	—
802.11g, 24 Mbps	—	-85.0	—
802.11g, 36 Mbps	—	-82.0	—
802.11g, 48 Mbps	—	-78.0	—
802.11g, 54 Mbps	—	-76.4	—
802.11n, HT20, MCS0	—	-93.0	—
802.11n, HT20, MCS1	—	-90.5	—
802.11n, HT20, MCS2	—	-88.2	—
802.11n, HT20, MCS3	—	-84.5	—
802.11n, HT20, MCS4	—	-81.5	—
802.11n, HT20, MCS5	—	-78.0	—
802.11n, HT20, MCS6	—	-75.5	—
802.11n, HT20, MCS7	—	-74.5	—
802.11n, HT40, MCS0	—	-90.0	—
802.11n, HT40, MCS1	—	-87.0	—
802.11n, HT40, MCS2	—	-84.6	—
802.11n, HT40, MCS3	—	-81.8	—
802.11n, HT40, MCS4	—	-78.0	—
802.11n, HT40, MCS5	—	-74.0	—
802.11n, HT40, MCS6	—	-72.8	—
802.11n, HT40, MCS7	—	-71.2	—

Table 7-5. Maximum RX Level

Rate	Min (dBm)	Typ (dBm)	Max (dBm)
802.11b, 1 Mbps	—	5	—
802.11b, 11 Mbps	—	5	—
802.11g, 6 Mbps	—	5	—
802.11g, 54 Mbps	—	0	—
802.11n, HT20, MCS0	—	5	—
802.11n, HT20, MCS7	—	0	—
802.11n, HT40, MCS0	—	5	—
802.11n, HT40, MCS7	—	0	—

Table 7-6. RX Adjacent Channel Rejection

Rate	Min (dB)	Typ (dB)	Max (dB)
802.11b, 1 Mbps	—	35	—
802.11b, 11 Mbps	—	35	—
802.11g, 6 Mbps	—	31	—
802.11g, 54 Mbps	—	14	—
802.11n, HT20, MCS0	—	31	—
802.11n, HT20, MCS7	—	13	—
802.11n, HT40, MCS0	—	25	—
802.11n, HT40, MCS7	—	13	—

7.2 Bluetooth 5 (LE) Radio

Table 7-7. Bluetooth LE RF Characteristics

Name	Description
Center frequency range of operating channel	2402 ~ 2480 MHz
RF transmit power range	-24.0 ~ 20.0 dBm

7.2.1 Bluetooth LE RF Transmitter (TX) Characteristics

Table 7-8. Bluetooth LE - Transmitter Characteristics - 1 Mbps

Parameter	Description	Min	Typ	Max	Unit
In-band emissions	$F = F_0 \pm 2 \text{ MHz}$	—	-37.62	—	dBm
	$F = F_0 \pm 3 \text{ MHz}$	—	-41.95	—	dBm
	$F = F_0 \pm > 3 \text{ MHz}$	—	-44.48	—	dBm
Modulation characteristics	$\Delta f_{1\text{avg}}$	—	245.00	—	kHz
	$\Delta f_{2\text{max}}$	—	208.00	—	kHz

Cont'd on next page

Table 7-8 – cont'd from previous page

Parameter	Description	Min	Typ	Max	Unit
	$\Delta f_{2avg}/\Delta f_{1avg}$	—	0.93	—	—
Carrier frequency offset	—	—	-9.00	—	kHz
Carrier frequency drift	$ f_0 - f_n _{n=2, 3, 4, \dots k}$	—	1.17	—	kHz
	$ f_1 - f_0 $	—	0.30	—	kHz
	$ f_n - f_{n-5} _{n=6, 7, 8, \dots k}$	—	4.90	—	kHz

Table 7-9. Bluetooth LE - Transmitter Characteristics - 2 Mbps

Parameter	Description	Min	Typ	Max	Unit
In-band emissions	$F = F_0 \pm 4 \text{ MHz}$	—	-43.55	—	dBm
	$F = F_0 \pm 5 \text{ MHz}$	—	-45.26	—	dBm
	$F = F_0 \pm > 5 \text{ MHz}$	—	-47.00	—	dBm
Modulation characteristics	Δf_{1avg}	—	497.00	—	kHz
	Δf_{2max}	—	398.00	—	kHz
	$\Delta f_{2avg}/\Delta f_{1avg}$	—	0.95	—	—
Carrier frequency offset	—	—	-9.00	—	kHz
Carrier frequency drift	$ f_0 - f_n _{n=2, 3, 4, \dots k}$	—	0.46	—	kHz
	$ f_1 - f_0 $	—	0.70	—	kHz
	$ f_n - f_{n-5} _{n=6, 7, 8, \dots k}$	—	6.80	—	kHz

Table 7-10. Bluetooth LE - Transmitter Characteristics - 125 Kbps

Parameter	Description	Min	Typ	Max	Unit
In-band emissions	$F = F_0 \pm 2 \text{ MHz}$	—	-37.90	—	dBm
	$F = F_0 \pm 3 \text{ MHz}$	—	-41.00	—	dBm
	$F = F_0 \pm > 3 \text{ MHz}$	—	-42.50	—	dBm
Modulation characteristics	Δf_{1avg}	—	252.00	—	kHz
	Δf_{1max}	—	200.00	—	kHz
Carrier frequency offset	—	—	-13.70	—	kHz
Carrier frequency drift	$ f_0 - f_n _{n=1, 2, 3, \dots k}$	—	1.52	—	kHz
	$ f_0 - f_3 $	—	0.65	—	kHz
	$ f_n - f_{n-3} _{n=7, 8, 9, \dots k}$	—	0.70	—	kHz

Table 7-11. Bluetooth LE - Transmitter Characteristics - 500 Kbps

Parameter	Description	Min	Typ	Max	Unit
In-band emissions	$F = F_0 \pm 2 \text{ MHz}$	—	-37.90	—	dBm
	$F = F_0 \pm 3 \text{ MHz}$	—	-41.30	—	dBm
	$F = F_0 \pm > 3 \text{ MHz}$	—	-42.80	—	dBm
Modulation characteristics	Δf_{2avg}	—	220.00	—	kHz
	Δf_{2max}	—	205.00	—	kHz
Carrier frequency offset	—	—	-11.90	—	kHz

Cont'd on next page

Table 7-11 – cont'd from previous page

Parameter	Description	Min	Typ	Max	Unit
Carrier frequency drift	$ f_0 - f_n _{n=1, 2, 3, \dots, k}$	—	1.37	—	kHz
	$ f_0 - f_3 $	—	1.09	—	kHz
	$ f_n - f_{n-3} _{n=7, 8, 9, \dots, k}$	—	0.51	—	kHz

7.2.2 Bluetooth LE RF Receiver (RX) Characteristics

Table 7-12. Bluetooth LE - Receiver Characteristic - 1 Mbps

Parameter	Description	Min	Typ	Max	Unit
Sensitivity @30.8% PER	—	—	-96	—	dBm
Maximum received signal @30.8% PER	—	—	5	—	dBm
Co-channel C/I	—	—	8	—	dB
Adjacent channel selectivity C/I	F = FO + 1 MHz	—	-4	—	dB
	F = FO - 1 MHz	—	-3	—	dB
	F = FO + 2 MHz	—	-32	—	dB
	F = FO - 2 MHz	—	-36	—	dB
	$F \geq FO + 3 \text{ MHz}^{(1)}$	—	—	—	dB
	$F \leq FO - 3 \text{ MHz}$	—	-39	—	dB
Image frequency	—	—	-29	—	dB
Adjacent channel to image frequency	F = $F_{image} + 1 \text{ MHz}$	—	-38	—	dB
	F = $F_{image} - 1 \text{ MHz}$	—	-34	—	dB
Out-of-band blocking performance	30 MHz ~ 2000 MHz	—	-9	—	dBm
	2003 MHz ~ 2399 MHz	—	-18	—	dBm
	2484 MHz ~ 2997 MHz	—	-16	—	dBm
	3000 MHz ~ 12.75 GHz	—	-6	—	dBm
Intermodulation	—	—	-44	—	dBm

¹ Refer to the value of Adjacent channel to image frequency when F = $F_{image} - 1 \text{ MHz}$.

Table 7-13. Bluetooth LE - Receiver Characteristic - 2 Mbps

Parameter	Description	Min	Typ	Max	Unit
Sensitivity @30.8% PER	—	—	-93	—	dBm
Maximum received signal @30.8% PER	—	—	2	—	dBm
Co-channel C/I	—	—	10	—	dB
Adjacent channel selectivity C/I	F = FO + 2 MHz	—	-7	—	dB
	F = FO - 2 MHz	—	-7	—	dB
	$F = FO + 4 \text{ MHz}^{(1)}$	—	—	—	dB
	F = FO - 4 MHz	—	-34	—	dB
	$F \geq FO + 6 \text{ MHz}$	—	-39	—	dB
	$F \leq FO - 6 \text{ MHz}$	—	-39	—	dB
Image frequency	—	—	-27	—	dB
Adjacent channel to image frequency	F = $F_{image} + 2 \text{ MHz}$	—	-39	—	dB

Cont'd on next page

Table 7-13 – cont'd from previous page

Parameter	Description	Min	Typ	Max	Unit
	$F = F_{image} - 2 \text{ MHz}^{(2)}$	—	—	—	dB
Out-of-band blocking performance	30 MHz ~ 2000 MHz	—	-17	—	dBm
	2003 MHz ~ 2399 MHz	—	-19	—	dBm
	2484 MHz ~ 2997 MHz	—	-16	—	dBm
	3000 MHz ~ 12.75 GHz	—	-22	—	dBm
Intermodulation	—	—	-40	—	dBm

¹ Refer to the value of Image frequency.

² Refer to the value of Adjacent channel selectivity C/I when $F = F_0 + 2 \text{ MHz}$.

Table 7-14. Bluetooth LE - Receiver Characteristic - 125 Kbps

Parameter	Description	Min	Typ	Max	Unit
Sensitivity @30.8% PER	—	—	-104	—	dBm
Maximum received signal @30.8% PER	—	—	5	—	dBm
Co-channel C/I	—	—	2	—	dB
Adjacent channel selectivity C/I	$F = F_0 + 1 \text{ MHz}$	—	-6	—	dB
	$F = F_0 - 1 \text{ MHz}$	—	-5	—	dB
	$F = F_0 + 2 \text{ MHz}$	—	-40	—	dB
	$F = F_0 - 2 \text{ MHz}$	—	-42	—	dB
	$F \geq F_0 + 3 \text{ MHz}^{(1)}$	—	—	—	dB
	$F \leq F_0 - 3 \text{ MHz}$	—	-46	—	dB
Image frequency	—	—	-34	—	dB
Adjacent channel to image frequency	$F = F_{image} + 1 \text{ MHz}$	—	-44	—	dB
	$F = F_{image} - 1 \text{ MHz}$	—	-37	—	dB

¹ Refer to the value of Adjacent channel to image frequency when $F = F_{image} - 1 \text{ MHz}$.

Table 7-15. Bluetooth LE - Receiver Characteristic - 500 Kbps

Parameter	Description	Min	Typ	Max	Unit
Sensitivity @30.8% PER	—	—	-99	—	dBm
Maximum received signal @30.8% PER	—	—	5	—	dBm
Co-channel C/I	—	—	3	—	dB
Adjacent channel selectivity C/I	$F = F_0 + 1 \text{ MHz}$	—	-5	—	dB
	$F = F_0 - 1 \text{ MHz}$	—	-7	—	dB
	$F = F_0 + 2 \text{ MHz}$	—	-39	—	dB
	$F = F_0 - 2 \text{ MHz}$	—	-40	—	dB
	$F \geq F_0 + 3 \text{ MHz}^{(1)}$	—	—	—	dB
	$F \leq F_0 - 3 \text{ MHz}$	—	-40	—	dB
Image frequency	—	—	-34	—	dB
Adjacent channel to image frequency	$F = F_{image} + 1 \text{ MHz}$	—	-43	—	dB
	$F = F_{image} - 1 \text{ MHz}$	—	-38	—	dB

¹ Refer to the value of Adjacent channel to image frequency when $F = F_{image} - 1 \text{ MHz}$.

8 Module Schematics

This is the reference design of the module.

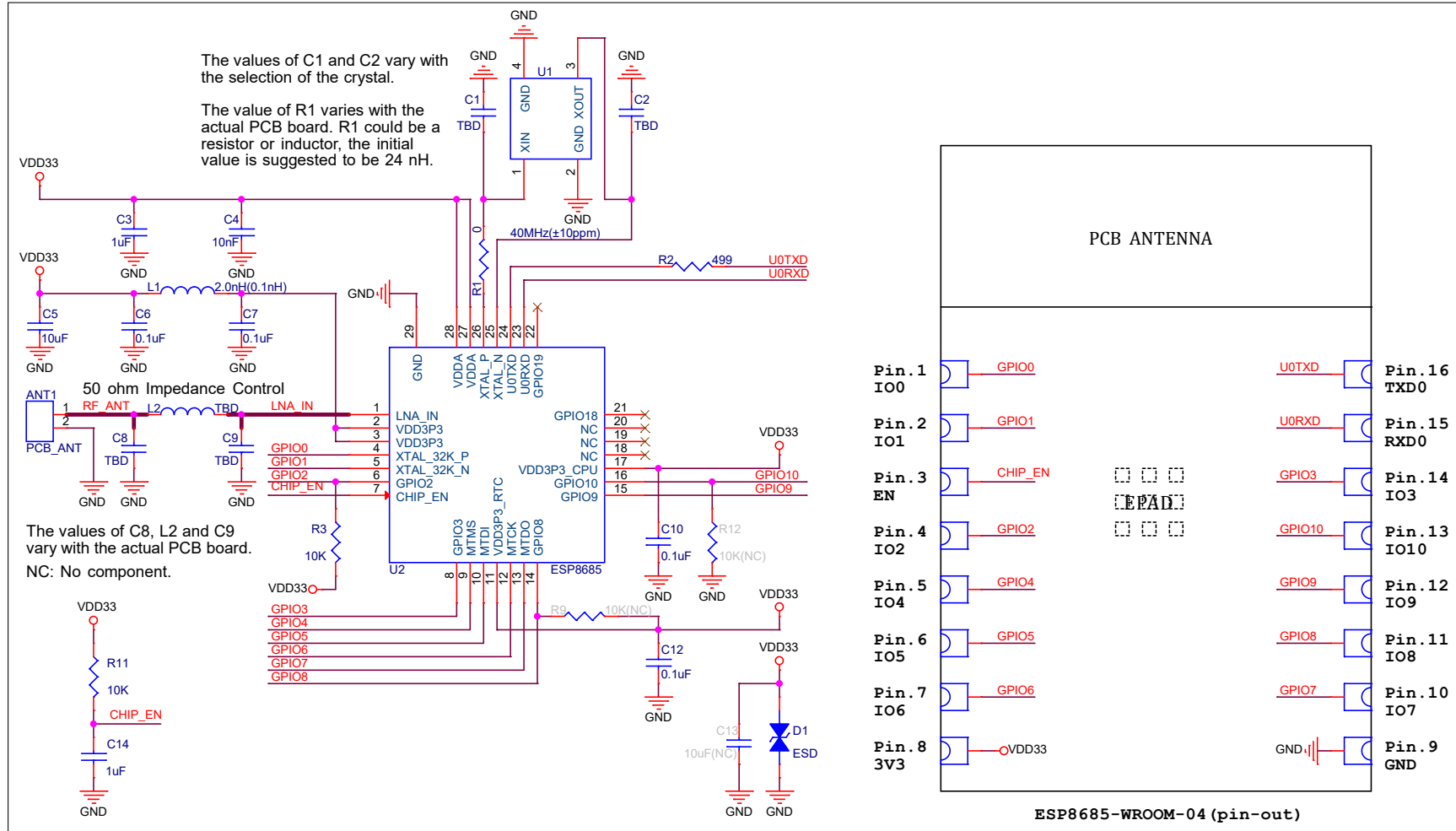

Figure 8-1. Schematics

10 Module Dimensions

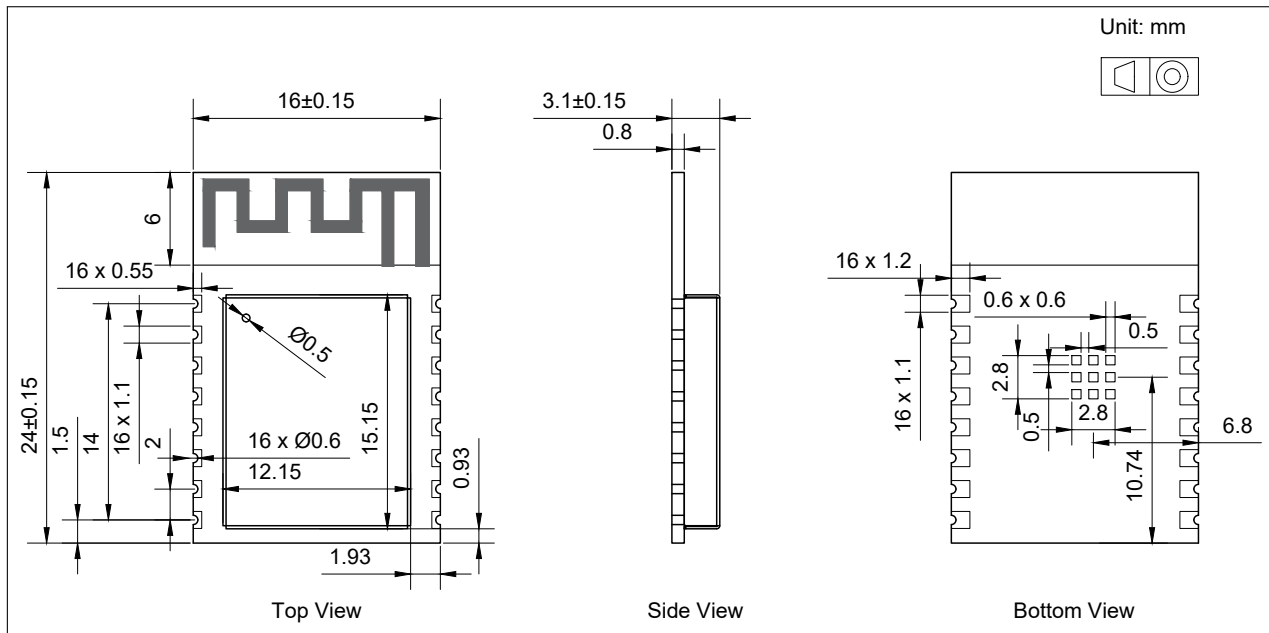

Figure 10-1. Physical Dimensions

Note:

For information about tape, reel, and product marking, please refer to [ESP32-C3 Module Packaging Information](#).

For details about module placement for PCB design, please refer to [ESP32-C3 Hardware Design Guidelines](#) > Section *General Principles of PCB Layout for Modules*.

12 Product Handling

12.1 Storage Conditions

The products sealed in moisture barrier bags (MBB) should be stored in a non-condensing atmospheric environment of $< 40\text{ °C}$ and 90%RH. The module is rated at the moisture sensitivity level (MSL) of 3.

After unpacking, the module must be soldered within 168 hours with the factory conditions $25\pm 5\text{ °C}$ and 60%RH. If the above conditions are not met, the module needs to be baked.

12.2 Electrostatic Discharge (ESD)

- Human body model (HBM): $\pm 2000\text{ V}$
- Charged-device model (CDM): $\pm 500\text{ V}$

12.3 Reflow Profile

Solder the module in a single reflow.

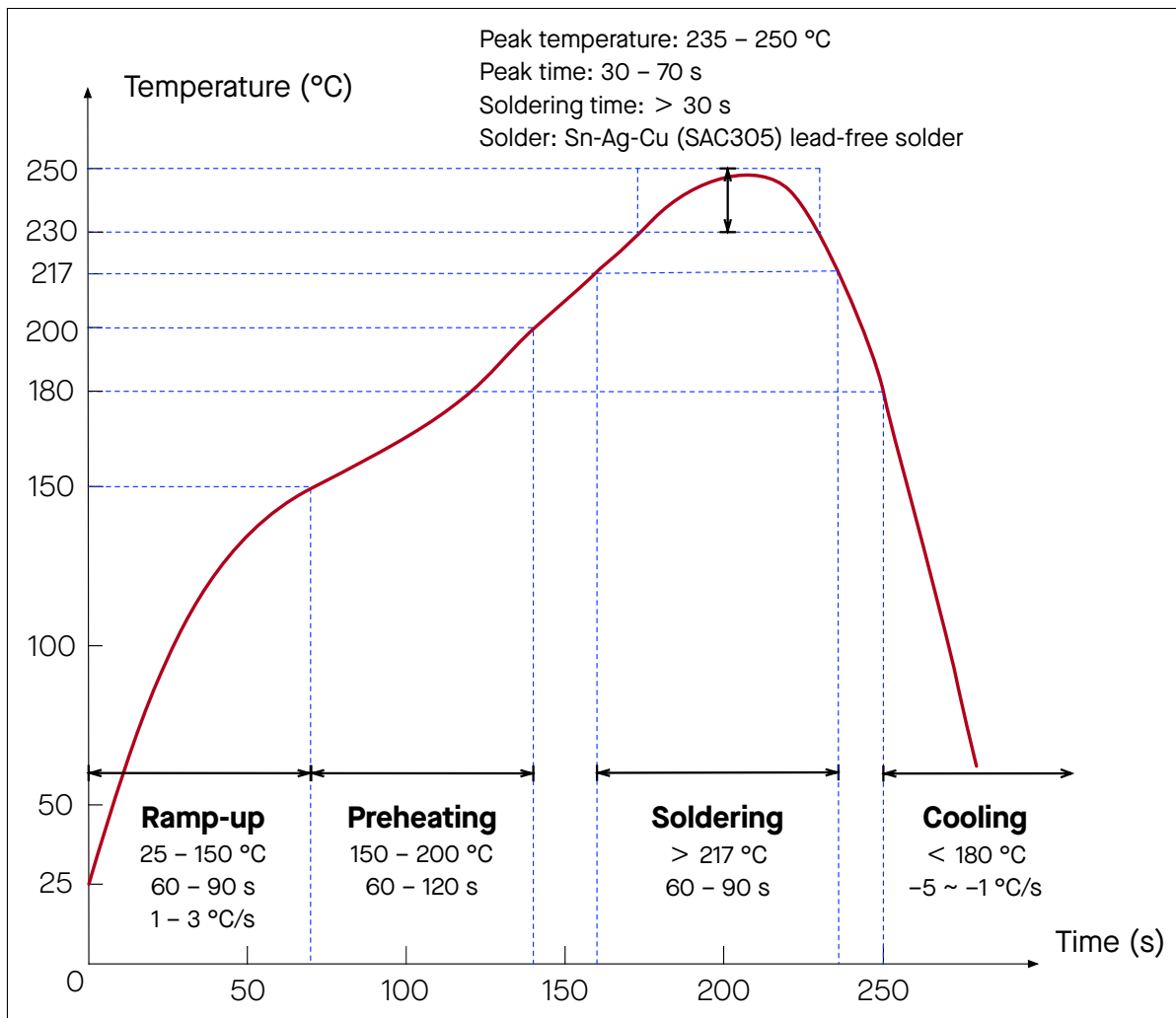

Figure 12-1. Reflow Profile

12.4 Ultrasonic Vibration

Avoid exposing Espressif modules to vibration from ultrasonic equipment, such as ultrasonic welders or ultrasonic cleaners. This vibration may induce resonance in the in-module crystal and lead to its malfunction or even failure. As a consequence, **the module may stop working or its performance may deteriorate.**

Datasheet Versioning

Datasheet Version	Status	Watermark	Definition
v0.1 ~ v0.5 (excluding v0.5)	Draft	Confidential	This datasheet is under development for products in the design stage. Specifications may change without prior notice.
v0.5 ~ v1.0 (excluding v1.0)	Preliminary release	Preliminary	This datasheet is actively updated for products in the verification stage. Specifications may change before mass production, and the changes will be documented in the datasheet's Revision History.
v1.0 and higher	Official release	—	This datasheet is publicly released for products in mass production. Specifications are finalized, and major changes will be communicated via Product Change Notifications (PCN) .
Any version	—	Not Recommended for New Design (NRND) ¹	This datasheet is updated less frequently for products not recommended for new designs.
Any version	—	End of Life (EOL) ²	This datasheet is no longer maintained for products that have reached end of life.

¹ Watermark will be added to the datasheet title page only when all the product variants covered by this datasheet are not recommended for new designs.

² Watermark will be added to the datasheet title page only when all the product variants covered by this datasheet have reached end of life.

Related Documentation and Resources

Related Documentation

- [ESP8685 Series Datasheet](#) – Specifications of the ESP8685 hardware.
- [ESP32-C3 Technical Reference Manual](#) – Detailed information on how to use the ESP8685 memory and peripherals.
- [ESP32-C3 Hardware Design Guidelines](#) – Guidelines on how to integrate the ESP8685 into your hardware product.
- [ESP32-C3 Series SoC Errata](#) – Descriptions of known errors in ESP8685 series of SoCs.
- *Certificates*
<https://espressif.com/en/support/documents/certificates>
- *ESP8685 Product/Process Change Notifications (PCN)*
<https://espressif.com/en/support/documents/pcns?keys=ESP32-C3>
- *ESP8685 Advisories* – Information on security, bugs, compatibility, component reliability.
<https://espressif.com/en/support/documents/advisories?keys=ESP32-C3>
- *Documentation Updates and Update Notification Subscription*
<https://espressif.com/en/support/download/documents>

Developer Zone

- [ESP-IDF Programming Guide for ESP8685](#) – Extensive documentation for the ESP-IDF development framework.
- *ESP-IDF* and other development frameworks on GitHub.
<https://github.com/espressif>
- *ESP32 BBS Forum* – Engineer-to-Engineer (E2E) Community for Espressif products where you can post questions, share knowledge, explore ideas, and help solve problems with fellow engineers.
<https://esp32.com/>
- *ESP-FAQ* – A summary document of frequently asked questions released by Espressif.
<https://espressif.com/projects/esp-faq/en/latest/index.html>
- *The ESP Journal* – Best Practices, Articles, and Notes from Espressif folks.
<https://blog.espressif.com/>
- See the tabs *SDKs and Demos, Apps, Tools, AT Firmware*.
<https://espressif.com/en/support/download/sdks-demos>

Products

- *ESP8685 Series SoCs* – Browse through all ESP8685 SoCs.
<https://espressif.com/en/products/socs?id=ESP8685>
- *ESP8685 Series Modules* – Browse through all ESP8685-based modules.
<https://espressif.com/en/products/modules?id=ESP8685>
- *ESP8685 Series DevKits* – Browse through all ESP8685-based devkits.
<https://espressif.com/en/products/devkits?id=ESP8685>
- *ESP Product Selector* – Find an Espressif hardware product suitable for your needs by comparing or applying filters.
<https://products.espressif.com/#/product-selector?language=en>

Contact Us

- See the tabs *Sales Questions, Technical Enquiries, Circuit Schematic & PCB Design Review, Get Samples* (Online stores), *Become Our Supplier, Comments & Suggestions*.
<https://espressif.com/en/contact-us/sales-questions>

Revision History

Date	Version	Release notes
2025-09-10	v1.5	<ul style="list-style-type: none"> Added Section 4.3 Chip Power-up and Reset Added Section 6.5 Memory Specifications Section 9 Peripheral Schematics: Added a note about AT communication using UART0 Added Datasheet Versioning
2024-07-29	v1.4	<ul style="list-style-type: none"> Updated the position of locating holes and the way to show EPAD dimensions in Chapter 10 Module Dimensions Improved the wording and structure of following sections: <ul style="list-style-type: none"> Updated Section "Strapping Pins" and renamed to 4 Boot Configurations Added Chapter 5 Peripherals Updated Table "Wi-Fi RF Standards" and renamed to "Wi-Fi RF Characteristics"
2024-02-06	v1.3	<ul style="list-style-type: none"> Removed the end-of-life ESP8685-WROOM-04-H2 variant
2024-01-15	v1.2	<ul style="list-style-type: none"> Updated Section 6.4.2 Current Consumption in Other Modes Updated "RF power control range" in Table Bluetooth LE RF Characteristics Updated Module Schematics Updated Peripheral Schematics, note 1, and note 2 Added descriptions and link of the source file in Section 11.1 PCB Land Pattern
2022-04-26	v1.1	<ul style="list-style-type: none"> Updated Section Module Schematics Updated Section Peripheral Schematics
2022-04-20	v1.0	<ul style="list-style-type: none"> Updated Section Bluetooth 5 (LE) Radio Added a new chip variant
2021-07-01	v0.6	<ul style="list-style-type: none"> Deleted Section "About This Document" Updated Section "Peripheral Schematics" Updated Section "Learning Resources" and renamed to "Related Documentation and Resources" Replaced "chip family" with "chip series" following Espressif's taxonomy
2021-06-11	v0.5	Preliminary release

Cont'd on next page

Cont'd from previous page

Date	Version	Release notes
2021-05-10	v0.1	Draft



Disclaimer and Copyright Notice

Information in this document, including URL references, is subject to change without notice.

ALL THIRD PARTY'S INFORMATION IN THIS DOCUMENT IS PROVIDED AS IS WITH NO WARRANTIES TO ITS AUTHENTICITY AND ACCURACY.

NO WARRANTY IS PROVIDED TO THIS DOCUMENT FOR ITS MERCHANTABILITY, NON-INFRINGEMENT, FITNESS FOR ANY PARTICULAR PURPOSE, NOR DOES ANY WARRANTY OTHERWISE ARISING OUT OF ANY PROPOSAL, SPECIFICATION OR SAMPLE.

All liability, including liability for infringement of any proprietary rights, relating to use of information in this document is disclaimed. No licenses express or implied, by estoppel or otherwise, to any intellectual property rights are granted herein.

The Wi-Fi Alliance Member logo is a trademark of the Wi-Fi Alliance. The Bluetooth logo is a registered trademark of Bluetooth SIG.

All trade names, trademarks and registered trademarks mentioned in this document are property of their respective owners, and are hereby acknowledged.

Copyright © 2025 Espressif Systems (Shanghai) Co., Ltd. All rights reserved.

www.espressif.com